

FORIGO

SINCE 1972

SPEEDY

Rigeneratrici per lettiera avicole
Litter renovators for poultry
Regenerador de camas avícolas



↔ **Compact**



**Natural
fermentation**



Comfort

SPEEDY 25



HP 20÷50
kW 15÷37



cm 100÷160
inch 39÷63



CUSCINETTI OSCILLANTI

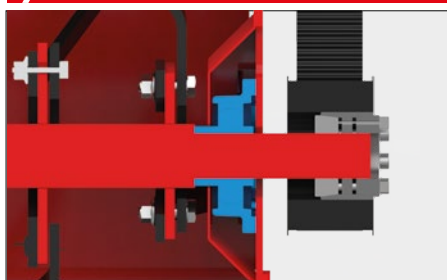

- Rotore montato su supporti a cuscinetti oscillanti.
- Rotor mounted on supports with swinging bearings.
- Rotor montado en soportes con cojinetes basculantes.

ZERO RUMORE



- Trasmissione a cinghia dentata (zero rumore).
- Transmission with toothed belts ("Zero noise").
- Transmisión por correa dentada (cero ruido).

MANUTENZIONE FACILE

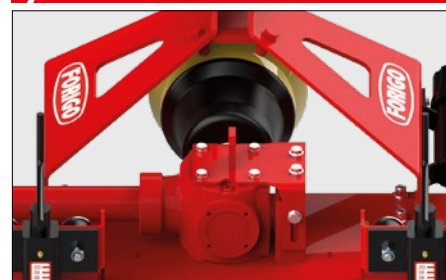

- Sistema di ingrassaggio facilitato.
- Easy greasing system.
- Sistema de engrase facilitado.

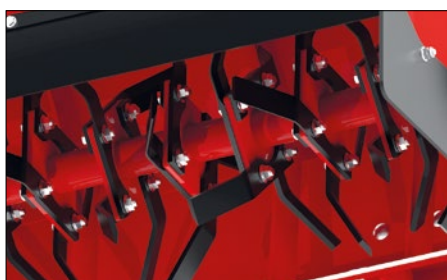

Mod							
	cm	inch	cm	inch		n.	Kg
SPD25 - 100	100	39	112	44	40	270	595
SPD25 - 120	120	47	132	52	48	295	650
SPD25 - 140	140	55	152	60	56	315	694
SPD25 - 160	160	63	172	68	64	340	750



SPEEDY 35

 **HP 40÷100**
kW 30-74

 **cm 150÷230**
inch 59÷91



ZERO MANUTENZIONE



- *Trasmissione laterale a catena completamente in bagno d'olio con tendicatena automatico a molla, questo permette di avere una macchina a manutenzione Zero.*



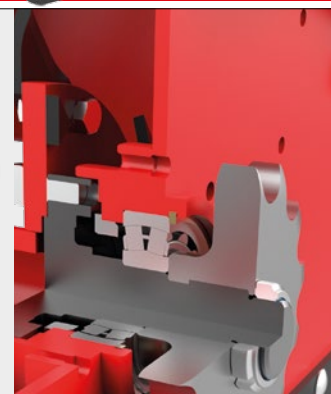
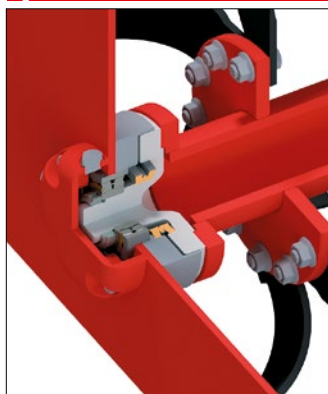

- *Lateral transmission with chain in oil bath with automatic chain tensioner on spring; it allows to have a "Zero maintenance" machine.*

- *Gracias a la transmisión lateral por cadena en baño de aceite con tensor de cadena de muelle automático la máquina no necesita mantenimiento.*

TENUTE OLIO



- *Rotore imbullonato sugli alberi laterali, tenute olio tipo CASSETTE*
- *Bolted rotor on the side shafts, CASSETTE oil seal system.*
- *Rotor atornillado en los ejes laterales, retenes tipo CASSETTE*

Mod							
	cm	inch	cm	inch		n.	Kg
SPD35 - 130	130	51	146	57	52	480	1058
SPD35 - 150	150	59	166	65	60	510	1124
SPD35 - 170	170	67	186	73	68	555	1224
SPD35 - 185	185	73	201	79	72	580	1279
SPD35 - 200	200	79	216	85	80	600	1323
SPD35 - 230	230	91	246	97	92	650	1433



Pronti a misurarci con te

ROTORE 4 VOLTE PIU' VELOCE!

Rotor 4 times faster!
¡Rotor 4 veces más rápido!

> 850 giri/min

A

- Questo permette di sminuzzare molto meglio la lettiera ed ha l'enorme vantaggio di far lavorare la trattoria a un basso numero di giri, evitando fastidiosi rumori.
- High rotor rpm combined with the great advantage of using the tractor at low PTO rpm and consequently better shuffling-shredding capacity and prevention of annoying noises.
- Permite desmenuzar mucho mejor la cama y tiene la gran ventaja de hacer trabajar el tractor con bajas revoluciones, evitando ruidos molestos.

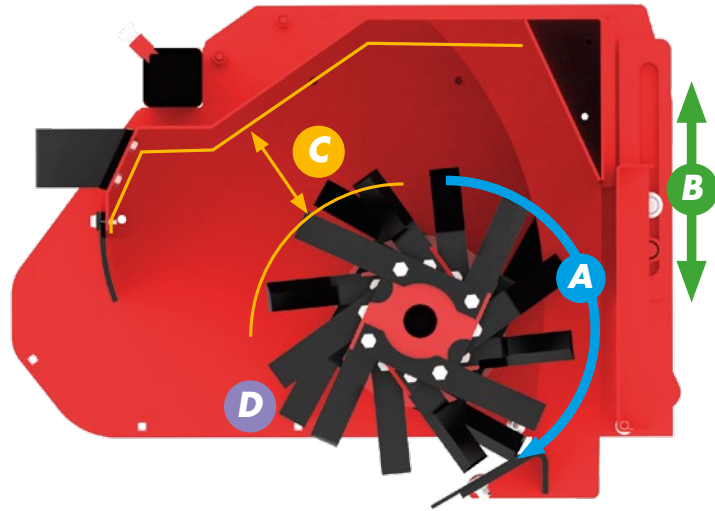

> Cofano regolabile

B

- Il cofano posteriore, regolabile in altezza, permette di controllare e livellare il flusso di prodotto in uscita, di conseguenza decidere il grado di affinamento; la stessa macchina può essere utilizzata su lettiera basse 8/10 cm oppure, aprendo il cofano può essere utilizzata per lettiera più alte 25/28 cm.
- The rear hood, adjustable in height, allows the user to control and level the product outgoing flow and accordingly the refinement level; the same machine can be used for low-level litters (8/10 cm) otherwise it can be used for higher-level litters (25/28 cm) by lifting the hood.
- El cofre trasero, regulable en altura, permite controlar y nivelar el flujo de salida del producto y, por lo tanto, decidir el nivel de refinamiento; la misma máquina puede ser utilizada para camas bajas (8/10 cm) o, abriendo el cofre, puede ser utilizada para camas más altas (25/28 cm).

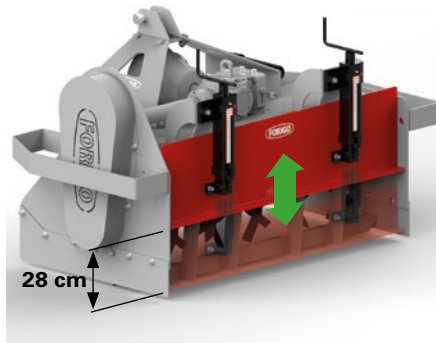

> Non si ingolfa

C

- Ampia distanza tra rotore e telaio, permette alla macchina di non ingolfarsi anche quando le lettiera sono abbondanti e molto umide.
- Large distance between rotor and frame, which prevents the machine stall even in case of very damp and plentiful litters.
- La amplia distancia entre rotor y chasis evita que la máquina se emboce también cuando las camas son abundantes y muy húmedas.

> Barra reversibile

D

- Barra reversibile; favorisce il sollevamento della lettiera per dirigerla verso il rotore.
- Reversible blade: facilitates litter lifting to go towards the rotor.
- Barra reversibile: favorece el levantamiento de la cama para dirigirla hacia el rotor



Perchè SPEEDY ?

• Le immagini della termocamera confermano l'importanza di trattare le lettiere con SPEEDY per avere una fermentazione omogenea e costante su tutto lo strato.

La parte inferiore è più calda perché c'è la fermentazione in atto, mentre la parte a contatto con gli animali è più fredda e umida.

L'utilizzo della SPEEDY inverte tutto questo, rendendo le lettiere più sane ed asciutte.



Superficie calda
Warm surface
Superficie caliente



Superficie fredda
Cold surface
Superficie fría



• The pictures obtained with the heat camera, demonstrate the importance of litter renovation treatment using the SPEEDY machine, in order to reach a constant and uniform fermentation of the entire litter surface. The lower part is warmer because the fermentation process is carrying on. On the other hand, the upper soil layer (in contact with the animals) is colder and damper. The SPEEDY usage keeps all the litter layers soft and very well ventilated.



• Las imágenes de la cámara térmica confirman la importancia de tratar las camas con SPEEDY para tener una fermentación homogénea y constante en toda la capa. La parte inferior es más caliente porque hay fermentación en curso, mientras que la parte en contacto con los animales es más fría y húmeda. El uso de SPEEDY inverte todo esto haciendo que las camas sean más sanas y secas.

Plantari più sani



• SPEEDY miscela e tritura la lettiera rendendola morbida ed arieggiata. Più benessere e meno problemi ai plantari per il vostro allevamento.

• SPEEDY mixes and crushes the litter making it soft and airy. More wellness and less problems for your livestock.

• SPEEDY mezcla y desmenuza la cama volviéndola blanda aireada. Más bienestar y menos problemas a las plantillas para vuestra cría.

Protezioni laterali



• Lateralmente la macchina è dotata di protezioni per evitare di creare problemi agli animali.

• The machine has lateral protections which can avoid creating problems to animals.

• En los laterales la máquina está equipada con protecciones que evitan problemas a los animales.

Minori costi di gestione



• Un solo operatore in 25 minuti può risanare la lettiera di oltre 1000 m² riducendo i costi di riscaldamento e aumentando la durata del letame.

• It takes 25 minutes to one operator to improve the litter of more than 1000 m² reducing warming costs and increasing manure duration.

• Un único usuario puede sanear una cama de más de 1000 m² en 25 minutos reduciendo los costes de calefacción y aumentando la duración del estiércol.

LA NOSTRA DIFFERENZA E' FARE LA MACCHINA COME VUOI TU

Our difference is manufacturing your machine tailor-made to your wishes.
Nuestra diferencia es realizar la máquina como deseas.

Pronti a misurarci con te

- Product ranges
- Líneas de producto

ERPICI ROTANTI

Power Harrows
Gradas rotativas



ZAPPATRICI

Rotary Tillers
Fresas



TRINCIATRICI

Shredders
Trituradoras



INTERRATRICI

Stone Buriers
Enterradoras



AIUOLATRICI

Bed Formers
Conformadoras



POLYFORMER

Polyformer
Polyformer



CO.MODUS

CO.Modus
CO.Modus



ROMPICROSTA

Crust Breaker
Rompe costra



RINCALZATORI BAULATRICI

Ridgers and Bed Former
Aporcadoras/Conformadoras



MODULA

Modula Seeder
Modula



TRINCIANDEFOGLIATORI

Leaf toppers
Trituradoras desfoliadoras



STERILIZZATRICI

Sterilizers
Esterilizadoras



PACCIAMATRICI

Mulching machines
Acolchadoras



SERIE HYDRO

Hydro series
Serie Hydro



SPEEDY

Litter renovators for poultry
Speedy



questa è la DIFFERENZA FORIGO

This is the FORIGO DIFFERENCE.
Esta es la DIFERENCIA FORIGO.

- **INNOVAZIONE**
 - Innovation
 - Innovación
- **PERSONALIZZAZIONE**
 - Customization
 - Personalización
- **AFFIDABILITA'**
 - Reliability
 - Fiabilidad
- **CONSULENZA**
 - Consulting
 - Asesoramiento

FORIGO

ROTERTALIA s.r.l.
via Abetone Brennero Nord, 9
46035 Ostiglia (Mantova) ITALY

info@forigo.it - tel. +39 0386 32691

www.forigo.it

