

**AIR DRIVE DISTRIBUTOR** *included in every seeding element*

- Centesimal tolerances aluminum body
- Exclusive fast opening / closing system
- Incorporated electric engine
- Disc support on bearing
- Rear PTFE disc gasket
- Front dampened PTFE disc gasket
- Inner adjustable plate for seed flow regulation
- Seed selector with micrometric regulation
- Counter seed selector with micrometric regulation
- Interchangeable elements in contact with the disc on springs
- Inner pressurised air pipe for disc cleaning
- Exclusive seed shaking system by vibrations
- 1.5 Lt hopper
- Upper hopper closure
- External transparent disc protection
- Lower interchangeable coulter

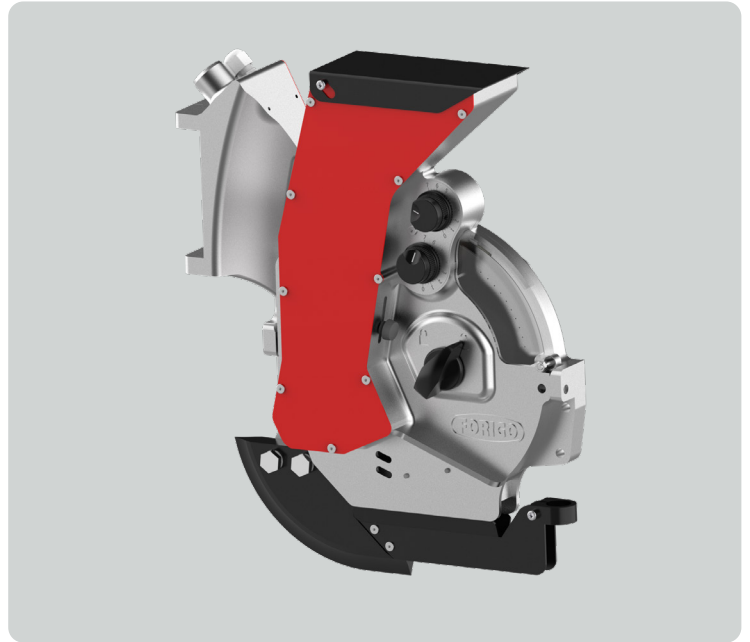

**Element SF TANDEM**

- Parallel link for precise ground following
- Springs on parallelogram for element's loading variation
- Front and rear wheel Ø250 mm with balance movement
- Wheel reversible scraper mounted on springs
- Mechanical seeding depth regulation by 2 crank handles
- Seed covering plate with tilting and pressure regulation
- Parallelogram locking system for transport
- Side adjustable DOUBLE AIR DRIVE seeding distributor

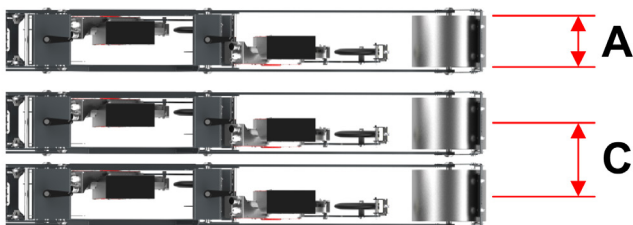

Model	Wheel width (A)		Minimum distance between seeding units (C)		Distance between sowing distributors (D)	
	cm	inch	cm	inch	cm	inch
SF24 TANDEM	17	6,7	24	9,4	min 1 - max 8	min 0,4 - max 3,1
SF28 TANDEM	17 - 20	6,7 - 7,9	28	11	min 1 - max 12	min 0,4 - max 4,7
SF33 TANDEM	20 - 22 - 25	7,9 - 8,7 - 9,8	33	13	min 1 - max 17	min 0,4 - max 6,7

## Other accessories

	Name	Description
	Stainless steel wheel	
	Mesh wheel	
	Flex rubber wheel	
	Front disc Ø170 mm (Single-row only)	
	Rubber seed presser wheel Ø185 x 20	Single
		Double
		Triple
	Aluminium seed presser wheel Ø170 x 20	Single
		Double
		Triple
	Photocell for the control of seeding fall and failures (each)	
	Additional seeding disc for pneumatic distributor	